

Track location	Ichihara		
Track name	Keitune		
Track length	318 m		
Race Event	IFMAR WC 2013		
Practice	Qualifying	Final	X
Race duration	60 min.		
Track layout	technical	X	fast mixed
Traction	medium	X	low high
Temperature	Air	25	Track
Results	Laps	Time	Position
	Fastest lap	Tank duration	

Engine			
Brand	Maxima	Type	
Glowplug	OS	Shims	
Carburator		Venturi	
Exhaust	Maxima		
Manifold			
Muffler			

Fuel	Brand	Maxima	Type	tarmac	Nitro	25 %
------	-------	---------------	------	---------------	-------	-------------

Clutch	Type	Shepherd std.		
Clutch shoe	Flyweights	Spring		
yellow	lightweight	std.		
Bell clearance	Preload			
0,5	2,7			

Drive ratio						
1st gear clutch bell	15		X	17	2nd gear clutch bell	
	16				19	X
1st gear gearbox	48		X	50	2nd gear gearbox	
	49				45	X

Tyres	Hotrace spec tyres		
Front left/right	Brand	Rear left/right	
/	/	/	
/	Shore	/	
69/69	Diameter start	76/76	
/	Diameter end	/	

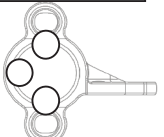
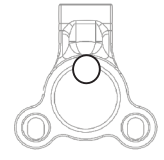
Excentric inserts		
Front		Rear
		

Radioplate	Fix	Flex	X
------------	-----	------	----------

Body	Brand	Protoform	Type	P909
Distance from bumper	18 mm			
Spoiler position	mm			

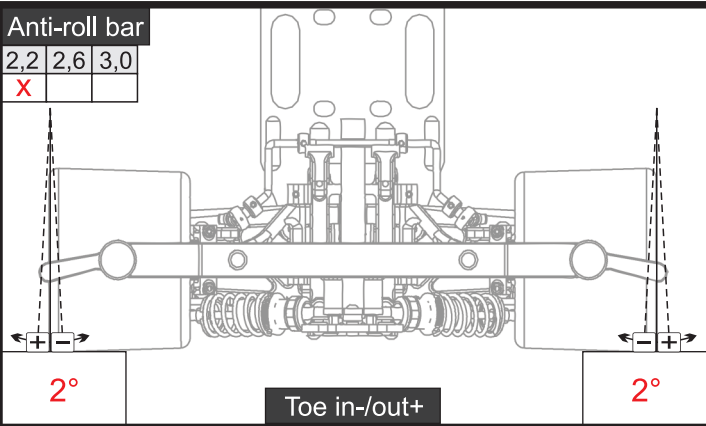
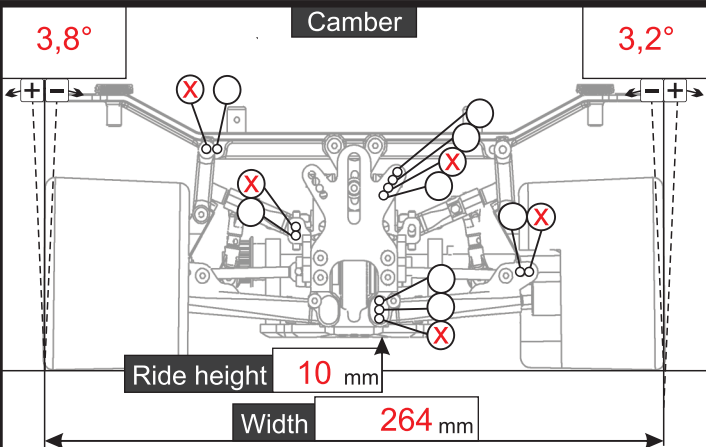
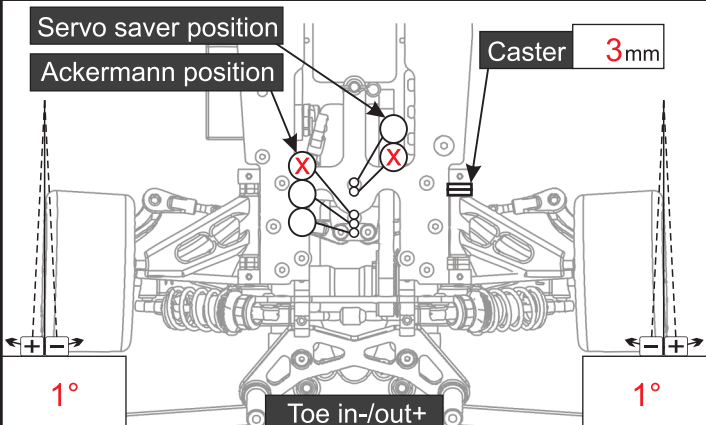
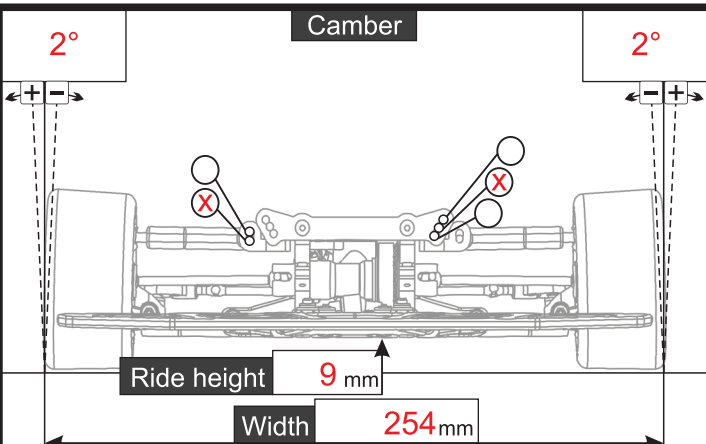

Shim	mm
Downstop	0 mm
Anti-roll bar	2,2 mm
Wheelbase	
	0mm 3mm X
Offset	0,5 mm

Shim	2 mm
Downstop	8 mm

Distance to Pivotball	mm
Position Anti-roll bar - lower wishbone	

Rear Shocks	1hole	X	2hole	3hole	Front Shocks	1hole	X	2hole	3hole
length: 80 mm					length: 68,75 mm				
Shock oil	650	Spring	green		Shock oil	650	Spring	green	

Notes

- 60g additional weight-mounted under the radioplate mount
- brass battery tray with LiFe battery
- body height 170mm