

Track location	Halifax		
Track name			
Track length	280 m		
Race Event	EFRA EC - A 2013		
Practice	Qualifying	Final	X
Race duration	45 min.		
Track layout	technical	X	fast mixed
Traction	medium	X	low high
Temperature	Air	25	Track
Results	Laps	175	Time 45'6.70 Position
	Fastest lap		Tank duration 5:10

Engine			
Brand	Maxima	Type	
Glowplug	OS	Shims	
Carburator		Venturi	
Exhaust	Maxima		
Manifold			
Muffler			

Fuel	Brand	Maxima	Type	tarmac	Nitro	16 %
------	-------	---------------	------	---------------	-------	-------------

Clutch	Type	Shepherd std.	
Clutch shoe	Flyweights	Spring	
yellow	lightweight	std.	
Bell clearance	Preload		
0,5	3,1		

Drive ratio						
1st gear clutch bell	2nd gear clutch bell					
15 X 17	19	20 X 21				
1st gear gearbox	2nd gear gearbox					
48 X 50	45 X 46	47				

Tyres	Contact spec tyres		
Front left/right	Brand	Rear left/right	
/	/	/	
/	Shore	/	
69/69	Diameter start	76/76	
/	Diameter end	/	

Excentric inserts		
Front		Rear

Radioplate	Fix	X	Flex
------------	-----	----------	------

Body	Brand	Protoform	Type	R18
Distance from bumper	18 mm			
Spoiler position	mm			

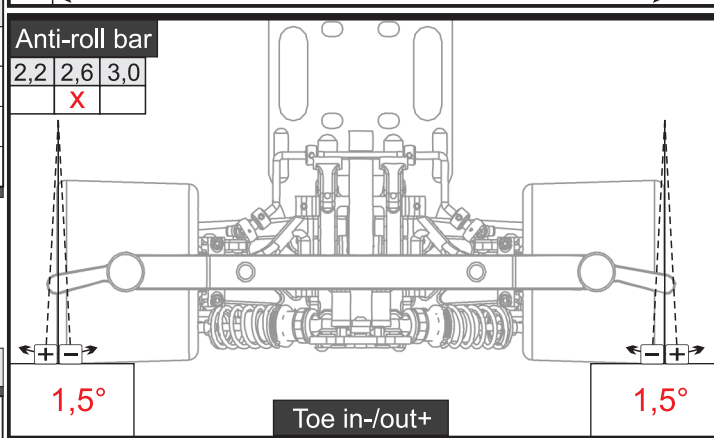
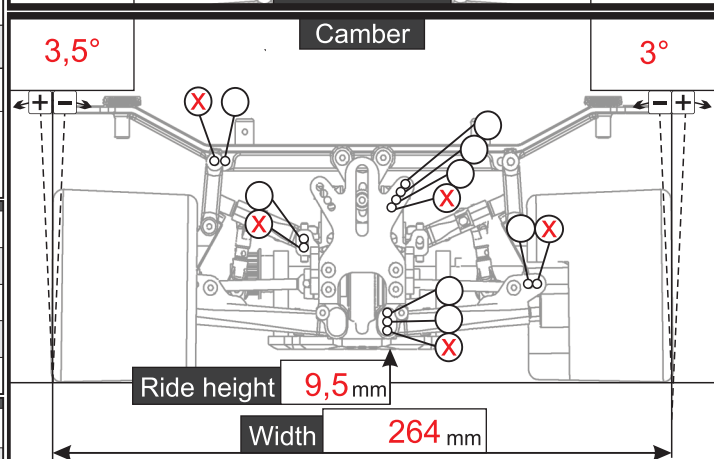
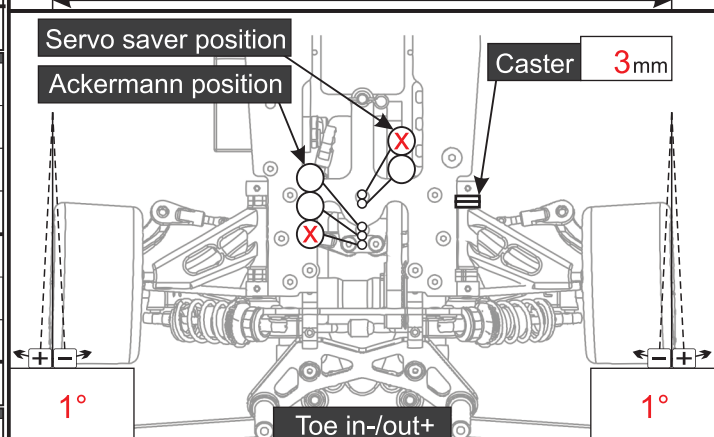
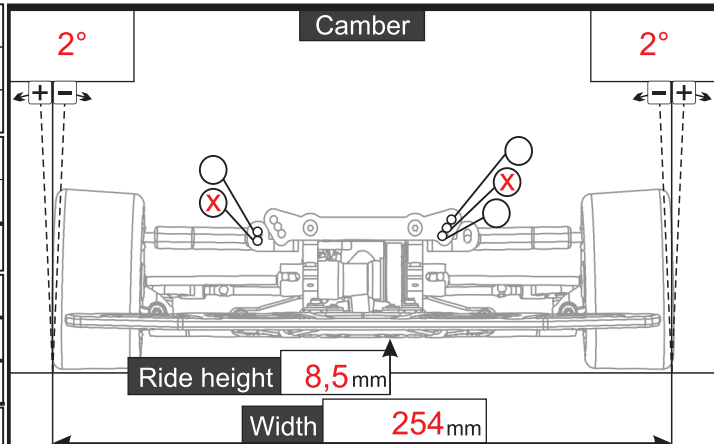

Shim	mm
Downstop	0 mm
Anti-roll bar	2,2mm
Wheelbase	
	0mm 3mm X
Offset	0,5mm

Shim	2 mm
Downstop	8 mm

Distance to Pivotball	mm
Position Anti-roll bar - lower wishbone	

Rear Shocks	1hole X 2hole 3hole	Front Shocks	1hole X 2hole 3hole
length: 80mm		length: 68,75 mm	
Shock oil	650	Spring	MG-gray
Shock oil	650	Spring	MG-gray

Notes

- 50g additional weight-mounted under the radioplate mount
- carbon battery tray with LiFe battery