

Track location	<b>Kirchberg Austria</b>
Track name	<b>Stöhr Ring</b>
Track length	<b>266 m</b>
Race Event	<b>ENS Round 2</b>
Practice	Qualifying <b>X</b> Final
Race duration	<b>45 min.</b>
Track layout	technical <b>X</b> fast mixed
Traction	low medium <b>X</b> high
Temperature	Air <b>25</b> Track
Results	Laps <b>140</b> Time <b>45:17.173</b> Position <b>1</b>
	Fastest lap <b>18.529</b> Tank duration <b>5 min.</b>

Engine	<b>Maxima</b>
Brand	Type
Glowplug	Shims
Carburator	Venturi
Exhaust	
Manifold	
Muffler	
Fuel	Brand <b>Maxima</b> Nitro <b>16 %</b>

Clutch	Type <b>Shepherd prototype</b>	
Clutch shoe	Flyweights	Spring
<b>yellow</b>	<b>std.</b>	<b>std.</b>
Bell clearance	Preload	
<b>0,5</b>	<b>0,8</b>	

Drive ratio	
1st gear clutch bell	2nd gear clutch bell
16 <b>X</b> 17 18	21 22 23 <b>X</b>
1st gear gearbox	2nd gear gearbox
58 <b>X</b> 59 60	53 54 <b>X</b> 55

Tyres	<b>Contact Spec tyres 40/37 - 64mm/62mm</b>	
Front left/right	Brand	Rear left/right
/	<b>Shore</b>	/
/	Diameter start	/
/	Diameter end	/

Front differential		
Differential	<b>X</b> Solid axle	One way
Oil	<b>300 000</b> cST	
Rear differential		
Oil	<b>80 000</b> cST	

Body	Brand <b>Protoform</b> Type <b>P37</b>
Distance from bumper	mm
Spoiler	width mm height mm
Position	distance to body rear mm
Winglets	mm x mm

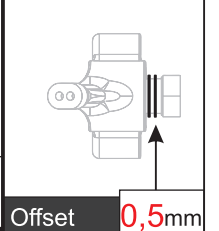
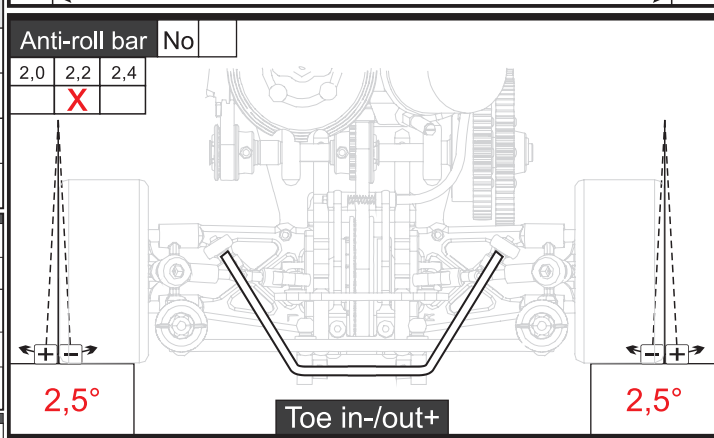
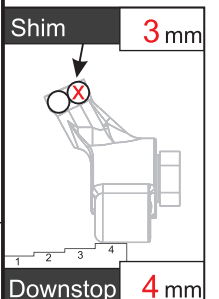
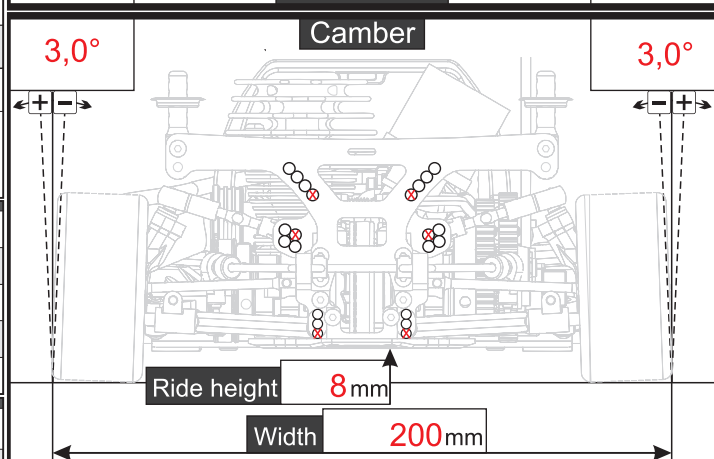
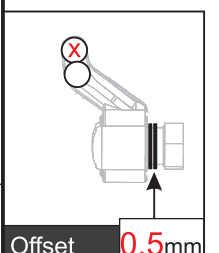
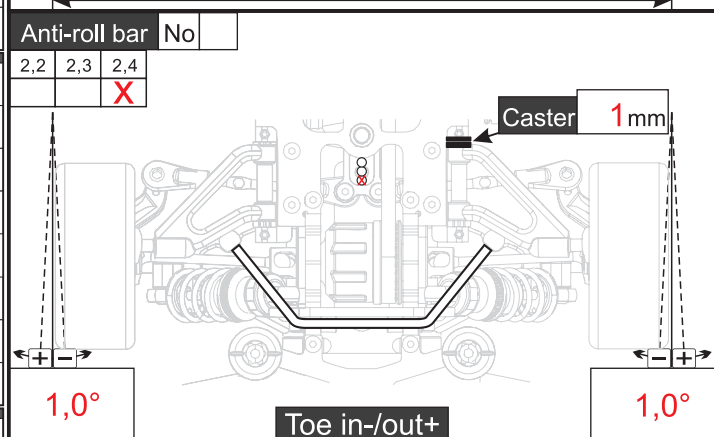
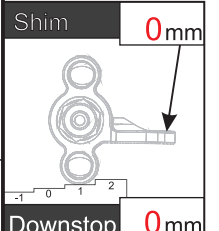
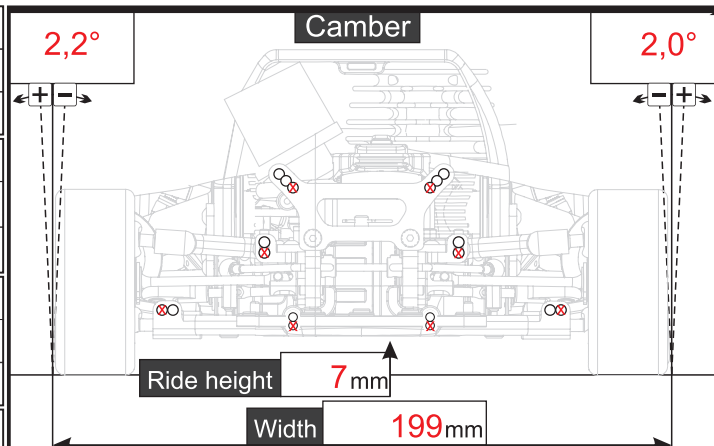

Rear Shocks	<b>length 67,00mm</b>	Front Shocks	<b>length 67,00mm</b>		
Piston 1hole	2hole	3hole <b>X</b>	Piston 1hole	2hole	3hole <b>X</b>
Spring floating piston	Soft	Hard	Spring floating piston	Soft	Hard
Shock oil	<b>500 cST</b>	Extra-Soft <b>X</b>	Shock oil	<b>500 cST</b>	Extra-Soft <b>X</b>
Spring	<b>Shepherd Black</b>		Spring	<b>Shepherd Black</b>	

Notes **Brass battery tray and 5 cell NiMh receiver battery**