

Name **Jilles Groskamp** Date **1 / 11 / 2009**

Track location **Hong Kong**
 Track name **TRC Raceway**
 Track length **260** m
 Race Event **Shepherd Asia Cup**
 Practice Qualifying Final
 Race duration _____ min.
 Track layout technical fast mixed
 Traction low medium high
 Temperature Air **28°C** Track **25°C**

Results Laps _____ Time _____ Position _____
 Fastest lap _____ Tank duration _____

Engine _____
 Brand _____ Type _____
 Glowplug _____ Shims _____
 Carburator _____ Venturi _____
 Exhaust _____
 Manifold _____
 Muffler _____
 Fuel Brand _____ Nitro _____ %

Clutch Type **VCC V10**
 Clutch shoe **black / std** Flyweights **std** Spring **hard / std**
 Bell clearance **0,5** Preload **0,35**

Drive ratio
 1st gear clutch bell 17 18
 2nd gear clutch bell 21 22 23
 1st gear gearbox 58 59 60
 2nd gear gearbox 53 54 55

Tyres
 Front left/right **ATS / ATS** Brand **Shore** Rear left/right **ATS / ATS**
37 / 37 **37 / 37**
62 / 61 Diameter start **64 / 63**
 Diameter end /

Front differential
 Differential Solid axle One way
 Oil **150 000** cST
 Rear differential
 Oil **50 000** cST

Body Brand **Shepherd** Type **Audi A5**
 Distance from bumper **0,0** mm
 Spoiler width **200** mm height **max.** mm
 Position distance to body rear **10** mm
 Winglets **35** mm x **20** mm

Notes **TQ & Win**

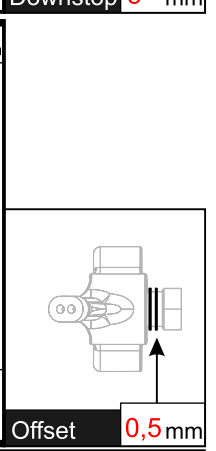
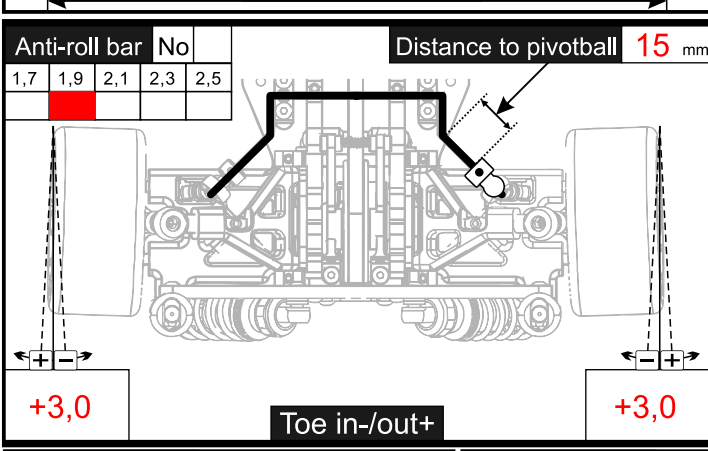
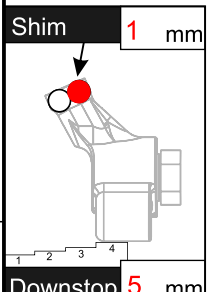
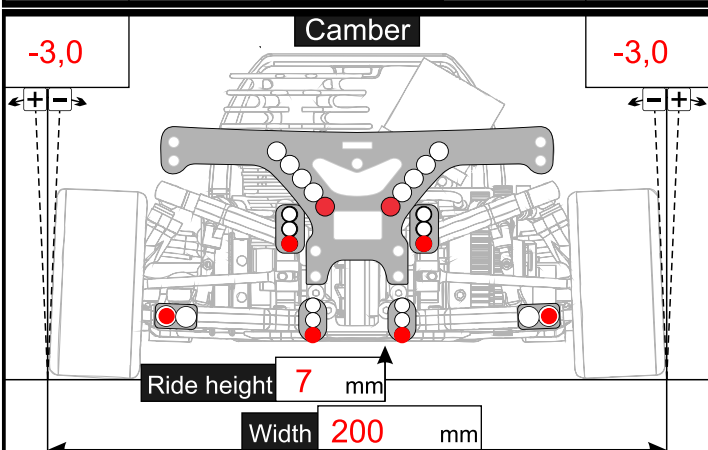
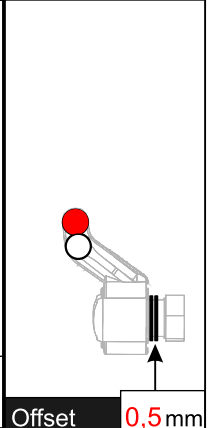
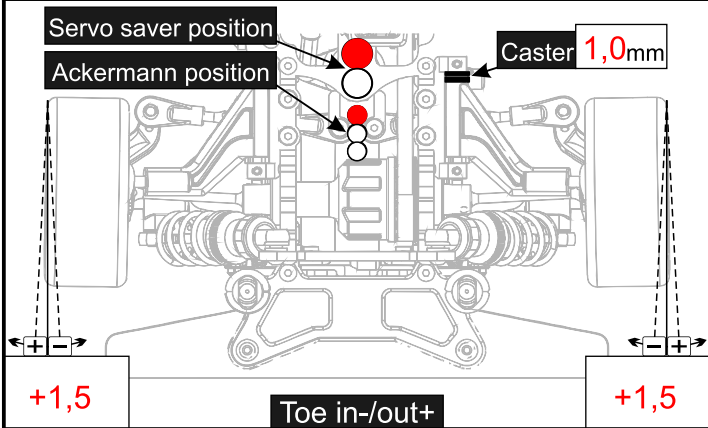
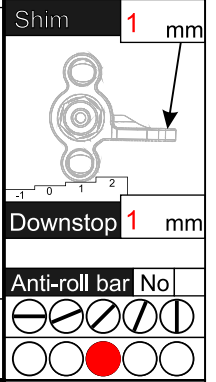
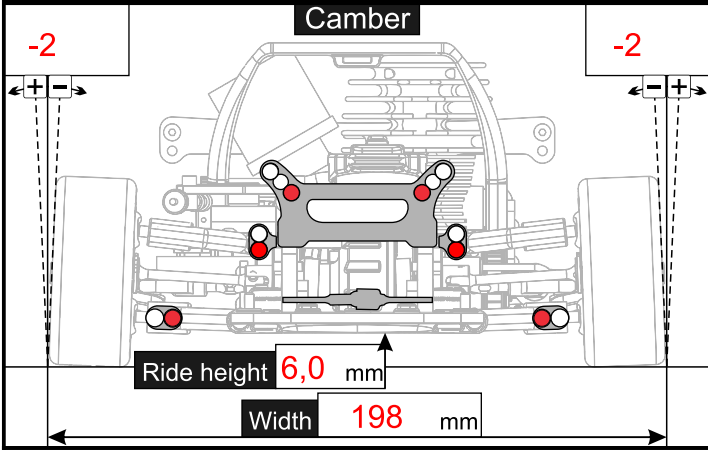

Rear Shocks
 Piston 1hole 2hole 3hole
 Spring floating piston Soft Hard
 Shock oil **500 cST**
 Spring **Shepherd green**

Front Shocks
 Piston 1hole 2hole 3hole
 Spring floating piston Soft Hard
 Shock oil **500 cST**
 Spring **Shepherd green**