

**Name:** Robert Pietsch  
**Date:** 20.04.2008 EFRA GP  
**Track:** Valencia / Spain

# VELOX SET-UP SHEET

SHEPHERD MICRO RACING

**Track condition:**  
 Surface:  SMOOTH  MEDIUM  BUMPY  
 Size:  TIGHT  MEDIUM  FAST  
 Traction:  LOW  MEDIUM  HIGH

Engine			
Engine	Muffler	Manifold	Plug
Nova 359	Nova 3007	Nova short	N7

Clutch		
Clutch shoe	Centrifugal shoe	Spring
Shepherd white	Std.	Std.

Clutch bell clearance/mm	Adj. nut position/mm
0,8	3,5

Drive ratio		
Pinion 1st	Pinion 2nd	Pulley
<input type="radio"/> 16 <input checked="" type="radio"/> 17	<input type="radio"/> 19 <input type="radio"/> 20 <input checked="" type="radio"/> 21	<input checked="" type="radio"/> 26 <input type="radio"/> 25

Spur 1st	Spur 2nd
<input type="radio"/> 48 <input type="radio"/> 49 <input checked="" type="radio"/> 50	<input type="radio"/> 45 <input checked="" type="radio"/> 46 <input type="radio"/> 47

Tyres		
Front left/right		Rear left/right
ATS / ATS	brand	ATS / ATS
32 / 32	shore	35 / 35
74 / 74	diameter start/mm	66 / 66
/	diameter end/mm	/

Body	
Body position/mm	Spoiler position/mm
4,5	5

Rear shock		
	Piston (hole)	2
	Oil	1000
	Spring	rot

Front shock		
	Piston (hole)	1
	Oil	650
	Spring	rot

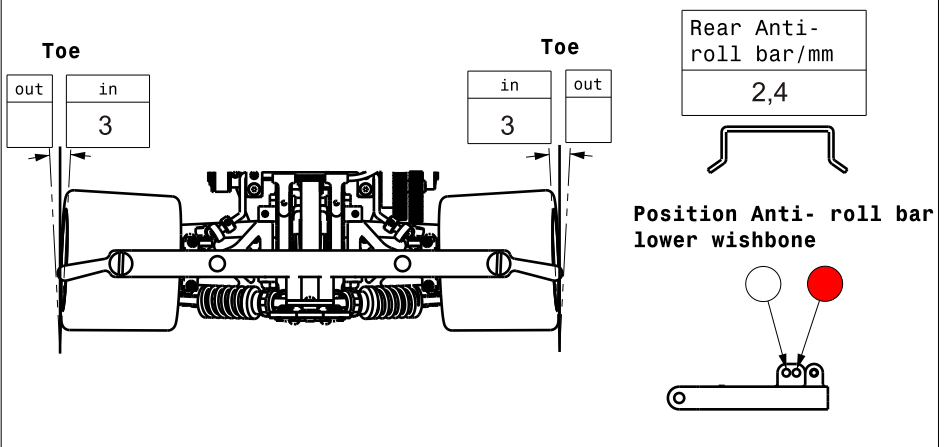
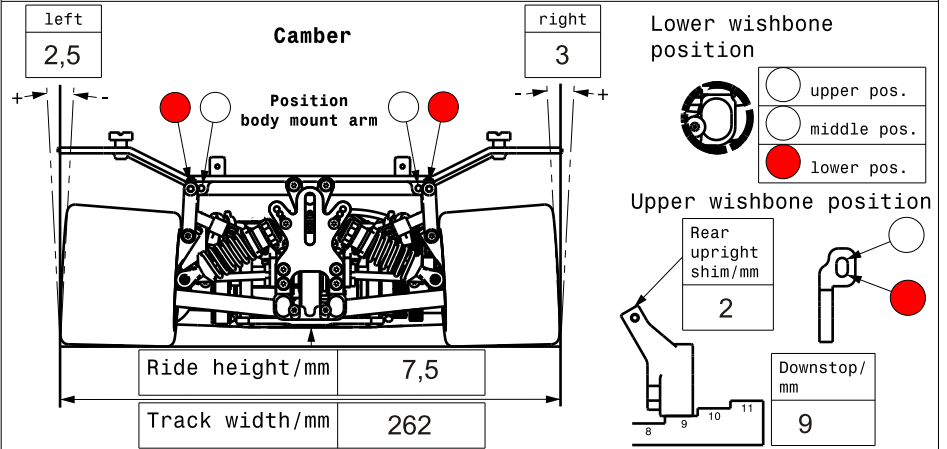
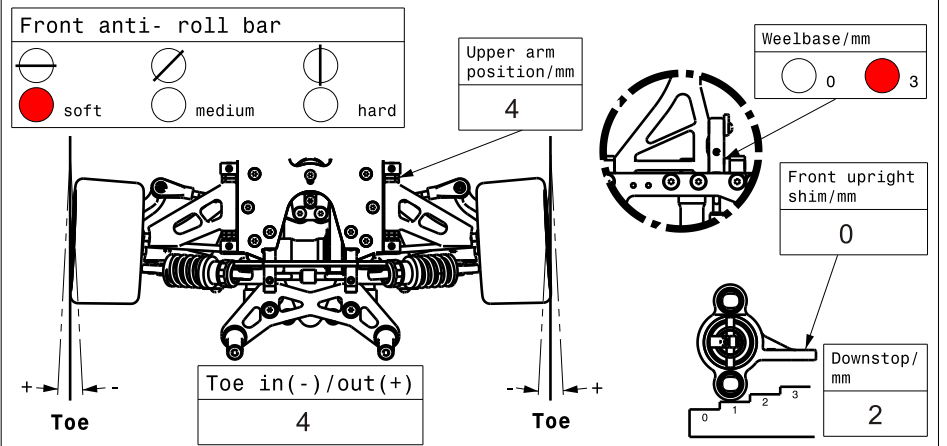
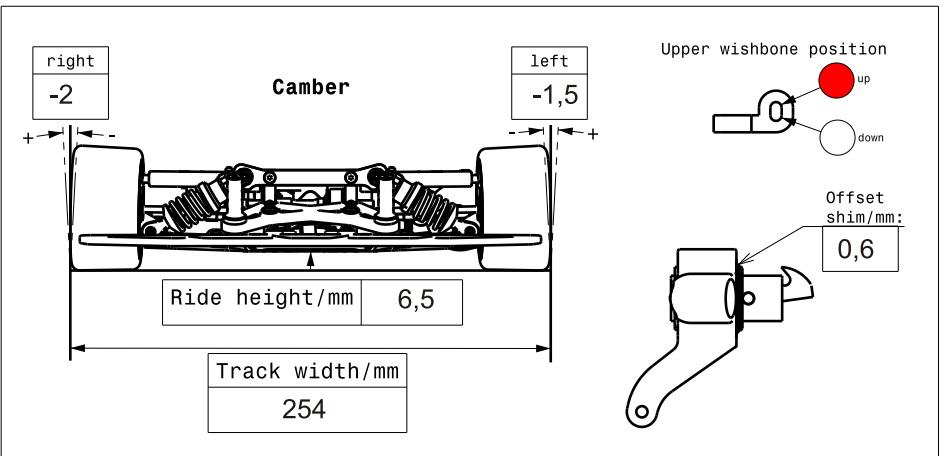
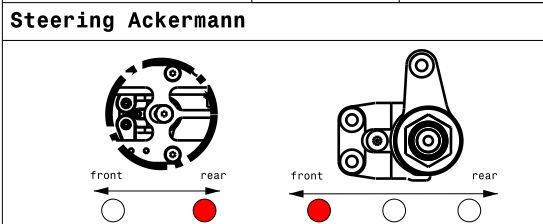

**Comments:**  
 TQ with 18laps  
 1st position in the final  
 New lap record 17.29